



TOYS

Noah's Ark

Mr. and Mrs. Noah and the animals pose for a group photograph before trooping into the Ark. Made from felt and polyurethane foam, these charming toys show a wealth of detail and imagination. Instructions are given for making the cardboard Ark, too.

Basic materials needed for making Mr. and Mrs. Noah and the animals are given below. Materials needed to cover and decorate each item are given under specific instructions.

You will need:

- Two large sheets of stiff paper, for patterns
- Two 18 inch squares of 1 inch deep polyurethane foam
- Black felt-tip pen
- Latex adhesive
- Xacto knife or a small hacksaw or fretsaw, to cut polyurethane

Mr. and Mrs. Noah

You will need:

- Materials given in general instructions
- One 12 inch square maroon felt
- One 5 inch by 3 inch piece peach felt
- One 5 inch square orange felt
- One 5½ inch square black felt
- One 5 inch by 3 inch piece light brown felt
- One 6 inch by 5 inch piece yellow-green felt
- 1 oz thin gold twine or knitting yarn, for Noah's crook
- One 4 inch square white felt
- Scraps of dark green, yellow, pink and mauve felt, and gold and pearl beads, for trimming
- 1 oz thick white knitting yarn
- 1 oz thick gold knitting yarn

To make Mr. Noah

Body: Cut two blocks of 1 inch deep polyurethane, each 5 inches by 2 inches, and stick them together with the adhesive. For the body covering, cut strips of felt, each 5 inches long, as follows: one ½ inch wide strip in maroon, one 1 inch wide strip in peach, one 1½ inch strip in orange and one 2½ inch wide strip in



▲ The dogs



▼ The snakes



▲ The horses

▼ The swans

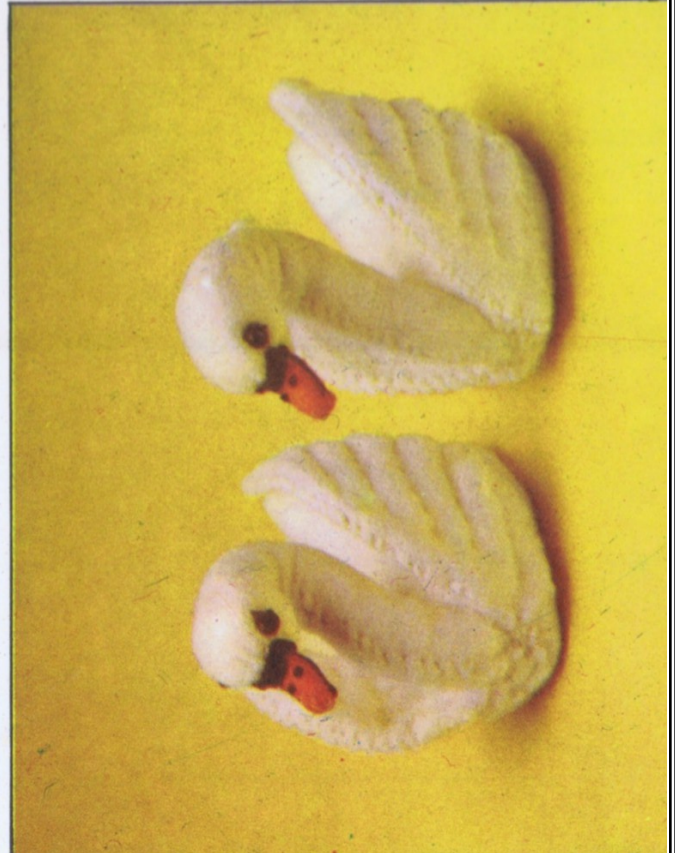

To make Mrs. Noah

Cut two blocks of foam the same size as those used for Mr. Noah, and stick them together. For the body, cut strips of felt, each 5 inches long, as follows: one ½ inch wide strip in light brown, one 1 inch wide strip in peach, one 3½ inch wide strip in yellow-green. Stitch the long sides of the strips together to make a 5 inch square.

To cover body: Wrap the felt around the foam with light brown felt to the top, and attach as for Mr. Noah. For the hat crown, cut a 1½ inch diameter circle in light brown and sew it to the top of Mrs. Noah's head. Make a hat brim as described for Mr. Noah, using light brown felt. Make Mrs. Noah's arms as for Mr. Noah, using peach and yellow-green felt, and stitch to her body.

For dress, frill, cut a strip of yellow-green felt, ½ inch wide and 9 inches long. Join the short ends, gather one long edge, slip over the base of Mrs.

Noah's body, and overcast in place. The features are either made from glued-on felt or embroidered.

Hair: Glue loops of thick gold knitting yarn to sides and back of head, stitching with matching thread. Pull loops to the center back of head and coil a separate strand of yarn around, to suggest a bun, stitching it to center back of head.

Trimming hat: Make a dove as for Noah, but add a separate wing shape in white felt, to one side. Stitch the dove to the center front of Mrs. Noah's hat, and surround it with tiny felt flowers.

To trim body: Trim Mrs. Noah's body with small pearl buttons, whittle two matchsticks to points, for knitting needles, and add thick blue yarn to represent knitting. Stitch the knitting in place in Mrs. Noah's hands, as shown. Make a disk to glue to base of figure as described for Mr. Noah, using cardboard and light brown felt.

Making the animals

You will need:

- 12 inch squares of felt in the following colors: pale orange, mid brown, black, white, mauve, lavender, pale pink, navy, maroon, peach, bright orange, blue, yellow, green, mustard, pale yellow, cream, russet brown, beige, dark brown, ginger, emerald green, deep pink
- One piece black felt, 18 inches long by ½ inch wide, for giraffes' manes
- 1 oz thick navy knitting yarn, for horses' manes
- 1 oz thick white knitting yarn, for swans
- 6-strand embroidery floss, in the following colors: mid brown, black, white, turquoise, pink
- Two packets pipe cleaners
- Small beads, sequins, gold braid etc., for trimmings
- Matching sewing threads



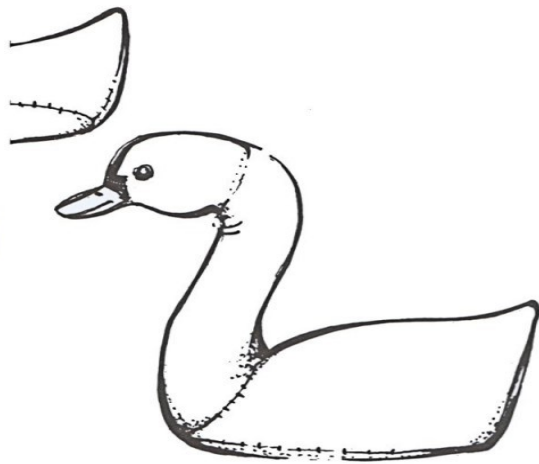
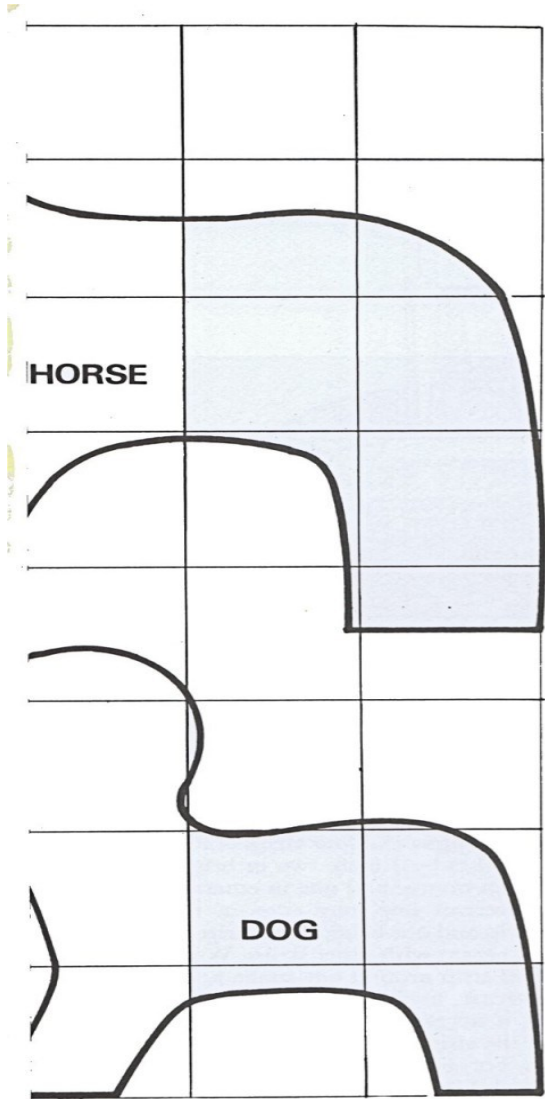

Fig. 3

- Absorbent cotton
- A large darning needle
- Two small dress weights

The patterns

Working from the graph, in which one square represents 1 inch, make one stiff paper pattern for the giraffe, the cat, the dog and the horse. The other animals are made without complete body patterns, but have various parts added. These pattern pieces are shown same-size on the chart, and can be traced off directly.

Cutting shapes from the foam

Place the paper pattern on the foam and, holding it steady, draw all around the shape with the felt-tip pen. Where possible, put the base of the leg shapes against the straight edge of the foam, so that the animals have a completely flat base to stand up on.

Cut two foam shapes for the giraffes and the horses, gluing them together with latex adhesive for extra thickness. The other animals are made from one thickness of foam.

Having drawn the shape of an animal on the foam, cut the straight edges of the shape with scissors; rounded edges are cut by holding the hacksaw or Xacto knife upright and working around each outline with an up-and-down sawing motion. Keep the blade at right angles to the sheet of foam.

The basic method for making and shaping animals

Most of the animals are made in this way. To cover the sides of a foam shape, dab latex or similar adhesive lightly on one side of the shape and press it down onto the felt. Trim the felt to the edge of the foam and repeat with the other side of the shape.

To shape animals

Before positioning gussets, shape animals by catching the edges of both felt side pieces together across the foam, with matching thread (figure 1). Shape necks and noses in this way.

Gussets: Measure around the foam outline of each animal to find the gusset length. Cut a strip of felt this length, making it $1\frac{3}{4}$ inches wide for the double thickness animals, $\frac{7}{8}$ inch wide for the single thickness animals. Stitch pieces of felt together to make up the length if necessary.

To attach the gussets: Dab adhesive lightly along the center of the uncovered foam edges and stick the gusset into place right around the animal outline, so that the join or joins come under the body or feet of the animals. Stab the

gusset at intervals with pins, to hold it while the adhesive dries. There will be overhanging edges of felt in the areas where the foam has been compressed, trim away the surplus to fit.

Using matching thread, neatly overcast both edges of the gusset to the edges of the side pieces, then overcast the short ends of the gusset strip together where they meet.

Giraffes

Using pale orange felt for the bodies and two thicknesses of foam for each animal, make up two giraffes, using the basic method described. Shape and compress the necks at front and back, to make them more slender.

Make **the manes** from strips of black felt, about 18 inches long by $\frac{1}{4}$ inch wide, sewing the strips in spirals down each giraffe's neck from forehead, extending down the back of the neck for about 4 inches. Make **the hooves** from black felt, as shown in picture, and indicate the legs by couching down double strands of black 6-strand embroidery floss.

Make **the tails** from strips of orange felt stitched around with loops of black stranded floss. For horns, cut a $2\frac{1}{2}$ inch long piece of pipe cleaner. Cut small slits on each side of each giraffe's forehead and push the pipe cleaner through the slits. Bend up the ends as shown and cover with small circles of mid brown felt. Using the same size shape given, cut four ears from pale orange felt and stitch to giraffes' heads. Make **the eyes** as shown in the detail picture, padding the female giraffes' eyelids with a little absorbent cotton. Make the features as shown in the picture.

Horses

Make the horses from two thicknesses of foam each, using the felts and other materials shown in the picture and shaping at necks and noses.

Dogs

Make the dogs from one thickness only of the foam, using the felts and other materials shown in the picture, shaping necks and noses. If the dogs will not stand securely, cover a small piece of cardboard with matching felt and attach to base of each leg.

Cats

Make two cats from one thickness only of the foam, using the felts and other materials shown in the picture, shaping necks and noses and inserting a 1 inch length of $\frac{7}{8}$ inch wide cream felt in the gussets, for fronts. Stitch this part between front and back legs.

1973

Fig. 5

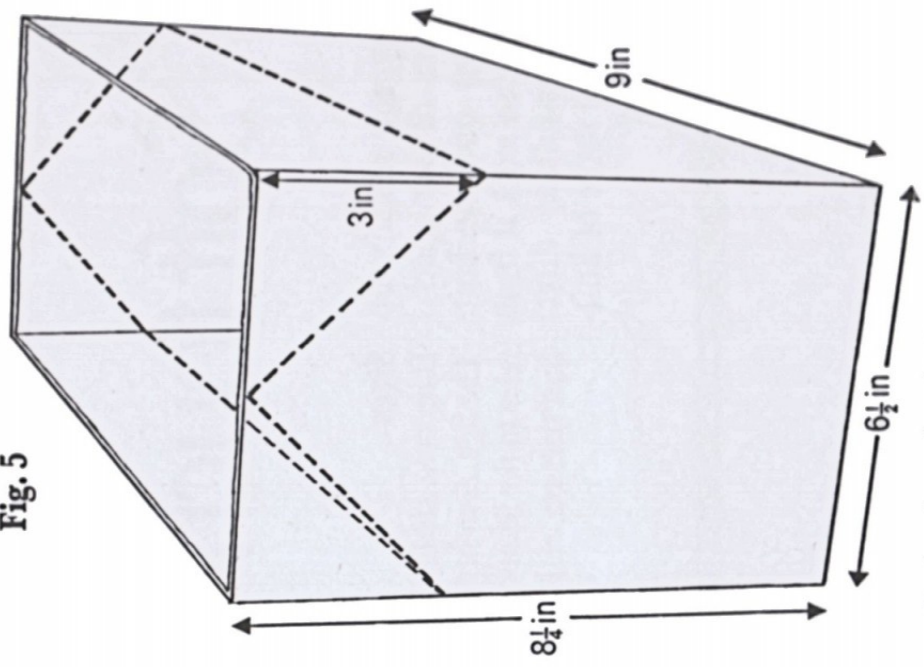

Trim smaller box for roof as shown

Fig. 4

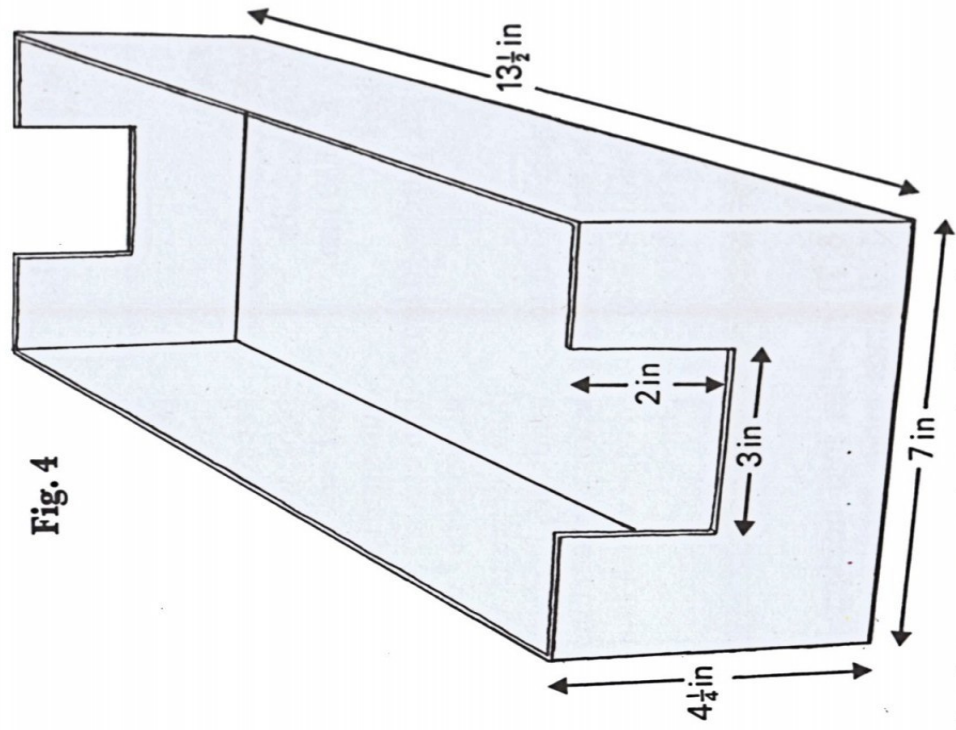

Cut shapes away at short ends of larger box

- Two 9½ inch by 4 inch pieces of cardboard
- Masking tape
- Two 6½ inch by 3¼ inch pieces of cardboard
- Two 3½ inch by 3 inch pieces of cardboard
- Small hacksaw or Xacto knife
- Scraps of wood-patterned wallpaper
- Wallpaper paste
- One cardboard box (the one illustrated measures 9 inches by 6½ inches, 8¼ inches deep)
- Two 24 inch square sheets white paper
- Adhesive or white glue
- 6 inch squares of yellow, purple and pink felt
- Two 9½ inch by 4½ inch pieces of cardboard
- Two 9¾ inch by 5¼ inch pieces of red bonded jersey fabric, for roof
- Pinking shears
- ¼ yard 36 inch wide printed cotton fabric, for lining cabin
- Scraps of braid to trim cabin
- Scraps of 1¼ inch deep eyelet embroidery, for window trimmings
- Piece of printed synthetic jersey fabric, 47 inches by 5 inches, to cover boat
- Scrap of synthetic fur fabric, to cover cabin floor

The following directions are for a Noah's Ark with finished measurements 27 inches by 13 inches.

Making the Ark

To make the boat shape: Cut a 3 inch

by 2 inch piece from both short ends of the larger box (see figure 4).

Bend the two 9½ inch by 4 inch pieces of cardboard in half, gently, and attach them to the short ends of the larger box with masking tape, so they represent bows and stern.

To make decks and gangways: Trim the two 6½ inch by 3¼ inch pieces of cardboard so they fit inside bows and stern and attach them inside each end with masking tape, 2 inches down from the top, so they are in line with the openings cut in the box.

Attach the 3½ inch by 3 inch pieces of cardboard with masking tape to the two decks thus made, and the base of the boat, so they form sloping gangways.

Portholes: Cut 1¾ inch diameter portholes in the long sides of the box, using the Xacto knife and starting the outside porthole 1¼ inches in from the corners.

To finish: Cover the sides and floors of the two decks and gangways and the upper side of the boat base with wood-patterned wallpaper.

To make cabin windows: Cut windows in the long sides of the smaller cardboard box, making each 2½ inches by 2 inches; center one window and cut two windows on either side of it, positioning them so each is ¼ inch from the box corners.

To join cabin to boat: Center the cabin on the boat shape and attach it with masking tape. Cover the four sides of the smaller box in white paper, using wallpaper paste to attach it and running

the paper down over the boat shape, to strengthen the join. Cut X-shapes over each window, push the paper to the inside, and paste down.

To trim: Make a felt front door and trim the windows with decorative scraps of felt in various colors, as shown in the picture.

The roof: Cover one side of each of the two pieces of 9½ inch by 4½ inch card with the pieces of red bonded jersey, for roof, glueing the jersey in position. Trim lower edges of jersey with pinkingshears. Cutting 3 inches down from the top, trim the smaller box, as shown in figure 5, to make the roof shape. Attach the pieces of jersey-covered cardboard to the top of each long side of the cabin with masking tape. This makes the roof, which can be opened. A shoelace in a bright color can be threaded through each side of the roof, so the ark can be opened up and fastened again as required.

Trimming the inside of the cabin: Cover the cabin interior with the printed cotton fabric, turning in the raw edges and glueing. Trim all around the top of the interior with a length of braid. Glue scraps of eyelet embroidery inside each window as shown, for curtains.

To complete: Cover the boat shape with the long piece of jersey fabric. Turn in the raw edges and glue, positioning the fabric so the join comes at bows or stern, glueing particularly thoroughly around the portholes. When adhesive is dry, carefully cut out portholes through the fabric with the craft knife.

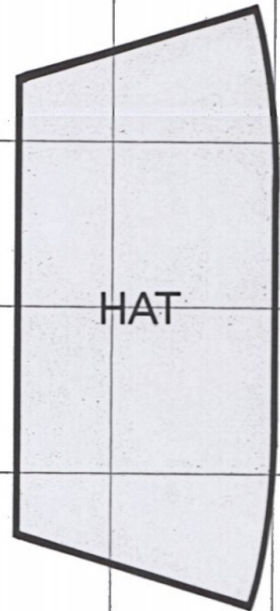

Graph pattern for mice

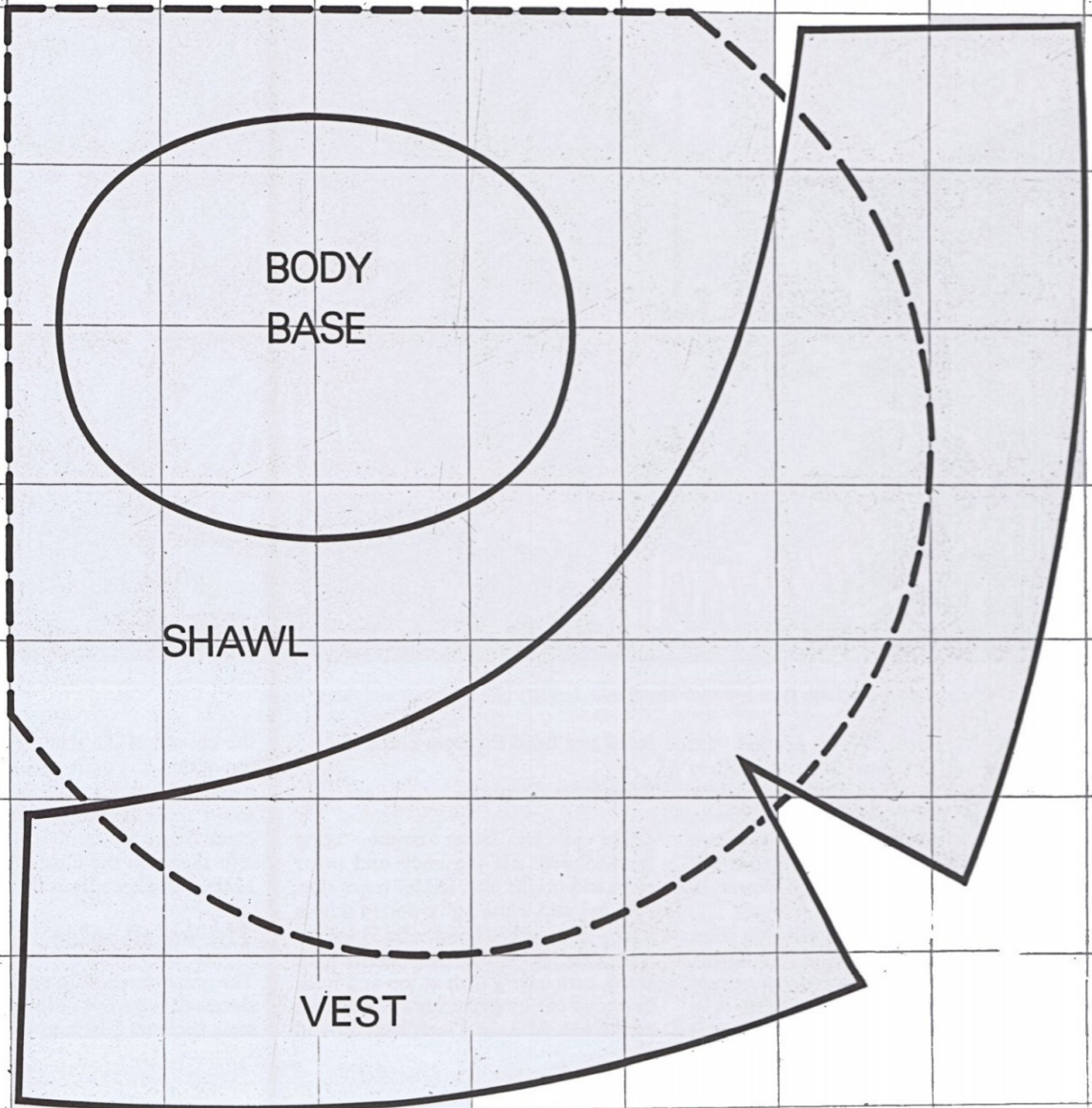



▲ The giraffes



▼ The penguins and the fish



Mr and Mrs Noah

▼ The cats



maroon. Stitch the long sides of the strips together, in the order given, to make a 5 inch square.

To cover the body: Wrap the joined strips of felt around the joined foam blocks, wrong side to the polyurethane foam, with the narrow maroon strip at the top. Overcast the edges of the felt together so that the join is in the center of one of the larger sides of the foam shape, stripes running horizontally.

Top of hat: Cut a 1½ inch diameter circle from maroon felt and sew it to the top of Noah's head. Using matching thread, run a gathering thread around the lower edge of the side of the hat crown, and draw it up slightly.

Hat brim: Cut a 2¾ inch diameter circle of thick cardboard and pierce a 1½ inch diameter circle in the center, without cutting into the outer circle. Cut two brim shapes from maroon felt and sew it to the inch diameter circle from the center, without cutting into the outer

circle. Cut two brim shapes from maroon felt, making each a fraction larger than the cardboard, and overcast them together with the cardboard in the middle. Push the brim down into position over the maroon felt crown, and catch-stitch firmly in place.

Arms: For each arm, cut a 5 inch length of pipe cleaner and fold it in half. Cut a 1 inch by ¾ inch piece of peach felt for each hand and fold it in half lengthwise. Glue each hand over the folded ends of the pipe cleaners, rounding off one corner.

Sleeves: Cut two pieces, each 1¾ inches by 1½ inches, from the orange felt. Fold each in half lengthwise, place one over each arm and stitch in place, so the hands are overlapped a little. Round off each sleeve head. Using matching thread, stitch the arms to Noah's sides, just below the join of the orange and peach felt.

Hair, beard and features: The hair

and beard are loops of thick white knitting yarn, couched down lightly. All the features are made from felt. Mark the legs in black yarn.

Dove and trimmings: Using the same-size shape given here, cut two dove shapes in white felt, adding a fringed tail. Pad the dove with a little absorbent cotton, add a yellow felt beak and embroider the wing and eye in black thread. Cut a green felt olive branch, glue it in the dove's beak, and stitch the dove to Noah's right hand. Trim Noah's front with two gold buttons, and make a crook shape with two pipe cleaners twisted together. Bind around the entire crook with gold twine and stitch it to Noah's left hand.

To make base: Cut a 2½ inch diameter cardboard circle and cover the sides with slightly larger circles of black felt. Overcast felt circles together. Glue and carefully stitch the black disk to the base of the figure.

Tracing patterns for the animals

1 square = 1 inch

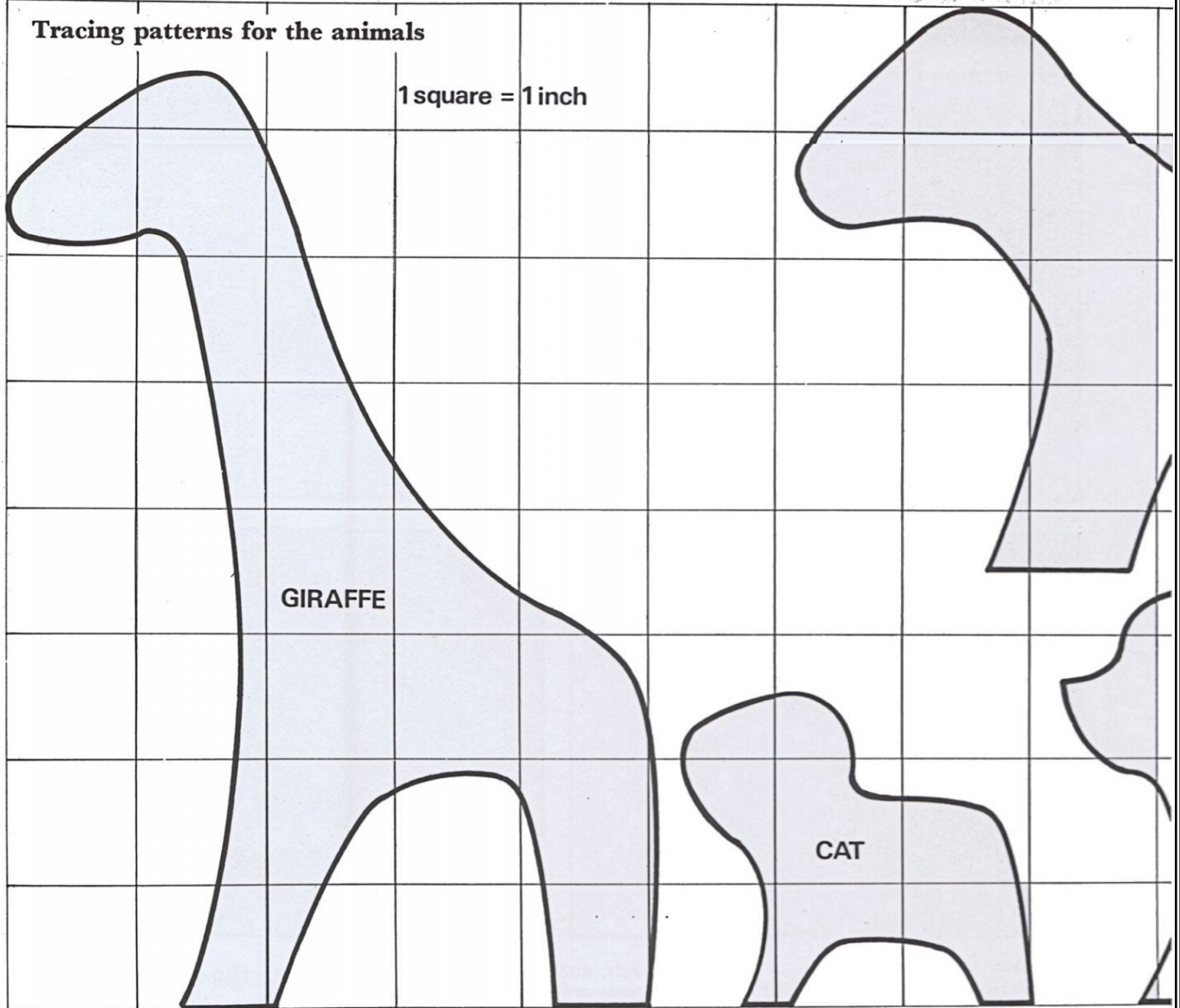

Actual size pieces

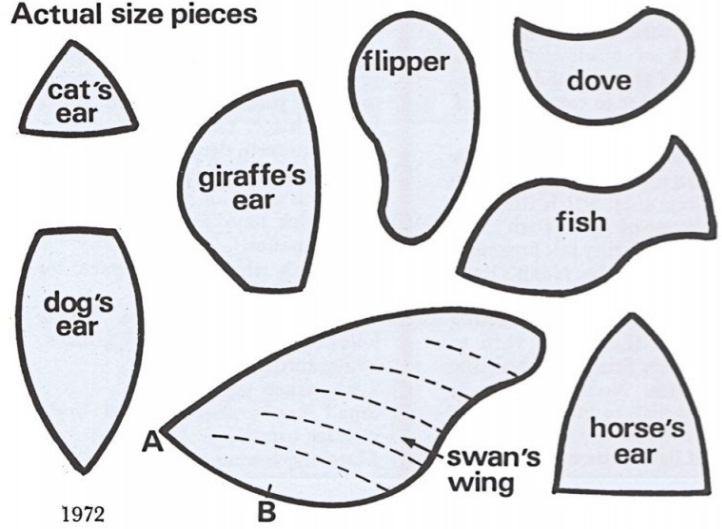

1972

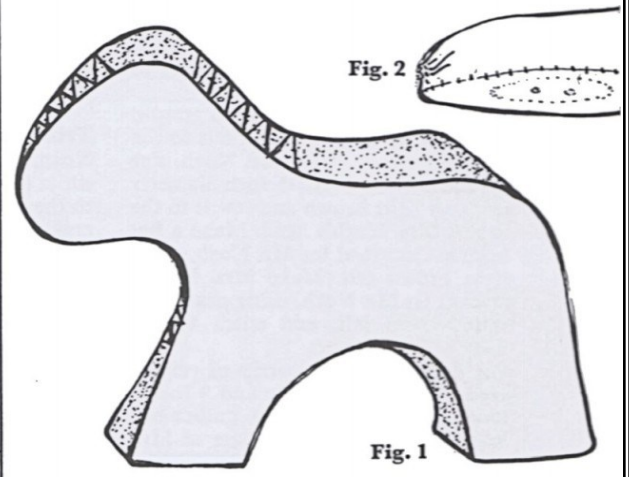

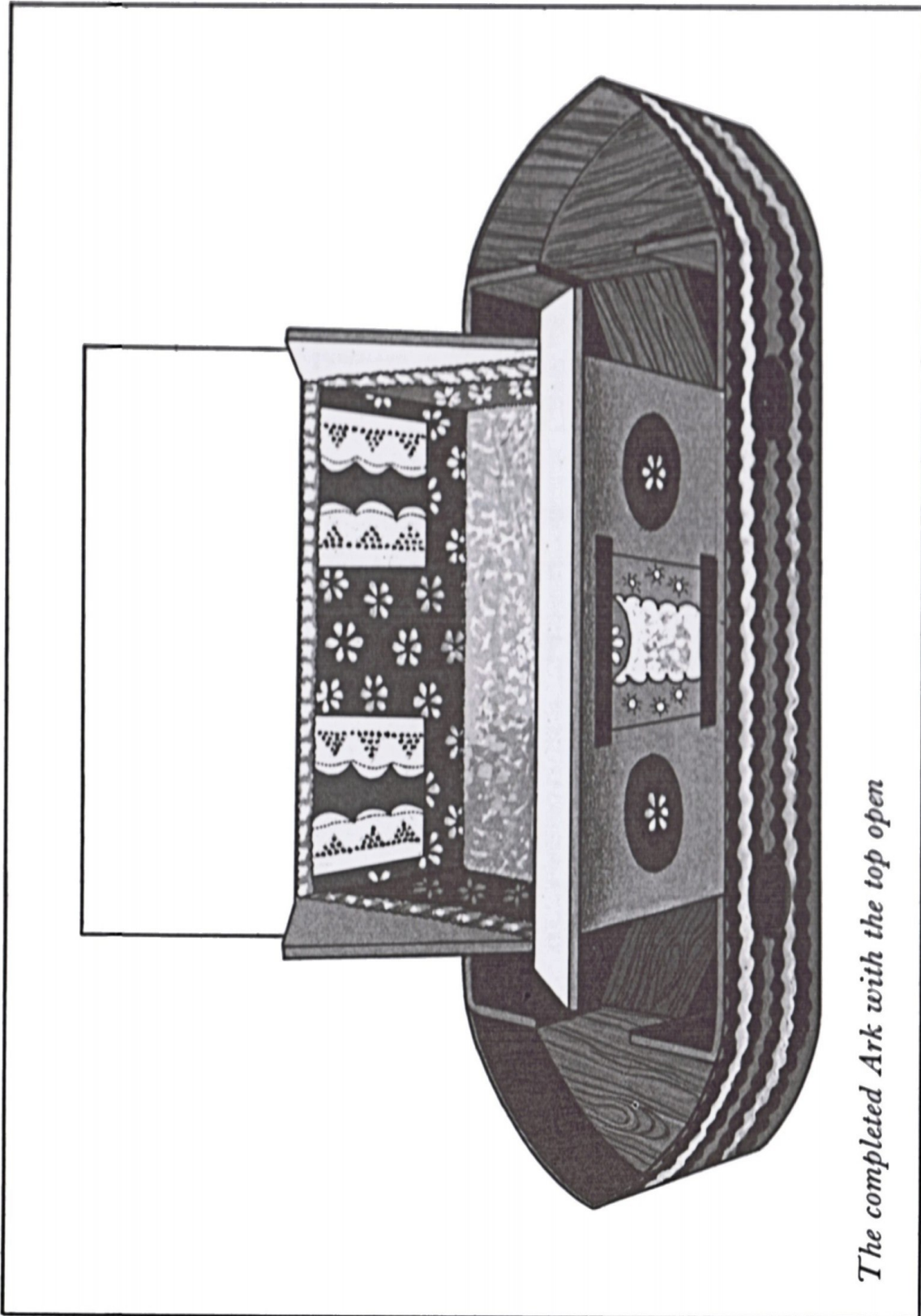

The completed Ark with the top open

Penguins

For each penguin, cut a 2 inch by $1\frac{3}{4}$ inch piece of 1 inch thick foam. For each body, cut a piece of white felt, $3\frac{1}{2}$ inches by $2\frac{1}{4}$ inches; wrap the felt around the foam and overcast the shorter edges together. Gather one edge of the felt and stitch the gathers (this becomes the top of the head). Repeat. Cut a $3\frac{1}{2}$ inch by $2\frac{1}{2}$ inch rectangle of black felt for each penguin. Join the short edges together for $\frac{3}{4}$ inch at one end and run a gathering thread around the joined long edge, to make a "wigwam" shape.

Pull the black felt shape over the white body and sew lower long edge of black shape to lower edge of white felt, leaving a triangular piece of white felt showing for penguin's front. Repeat. Make beaks, feet and eyes, as shown in picture.

Bases: For each penguin cut a $1\frac{1}{2}$ inch diameter circle of black felt. Trim where necessary and stitch to base of each bird.

Wings: Cut four white wings and four black wings, from felt. Sew together in pairs and stitch two wings to each penguin, as shown in picture.

Fishes: Using the same size shape given, cut four shapes in yellow felt. Stitch together, padding lightly with cotton and add eyes and mouths as shown. Embroider straight tail markings and buttonhole stitch scales in orange floss. Glue a fish under each penguin's left wing.

Swans

Cut two ovals of 1 inch thick plastic foam, 2 inches long by $1\frac{1}{4}$ inches wide and two rectangles of white felt, $2\frac{3}{4}$ inches by $2\frac{1}{2}$ inches. Taper each short side of one felt piece so one long side measures $1\frac{1}{4}$ inches. Fold the felt in half lengthwise so tapering sides are together, and stitch up the longer short side. This is the tail end. Turn the felt so the join is on the inside and gather up the shorter end as much as possible. Repeat.

Bases: Cut four ovals in white felt, the same size as the foam ovals, and sew together in pairs, inserting a small dress weight in each. Glue the felt ovals to the foam ovals. Pin the shaped upper body pieces to the uncovered side of the foam bases, with the tail ends centered at one end of each oval. Overcast the edges of bases and upper bodies together (figure 2).

Necks: Cut four $3\frac{1}{2}$ inch lengths of pipe cleaner and twist two together. Cut a $\frac{1}{2}$ inch square of orange felt and glue and stitch to cover one end of the pipe cleaners, for beak. Cut a $3\frac{1}{4}$ inch by $1\frac{1}{4}$ inch piece of white felt, for the rest of the neck. Wind thick white knitting yarn closely around the uncovered portion of the pipe cleaners, to pad the neck, then

fold the felt in half lengthwise around it. Using matching thread, overcast the edges of the felt together, padding where necessary with tiny pieces of cotton. Repeat.

Heads: Cut two pieces of $1\frac{1}{4}$ inch by $\frac{1}{2}$ inch white felt; stitch short ends together. Slip this small tube over necks of swans, just above the beaks, and run a gathering thread through each free edge. Insert a little cotton to round out the heads, draw up the gathering threads, and overcast heads to necks. Mark nostrils and beaks as shown, and stitch tiny black beads to each head, for eyes (figure 3).

Joining necks to bodies: Place the lower end of the neck to the gathered front of the body and, with the end of the neck even with the base, stitch neck in place, drawing the felt of the body around the base of the neck. Bend neck into a curve. Repeat.

Wings: Using the same-size shape shown here, cut eight wings in white felt. Overcast together in pairs along the upper edge, from A to the tip. Cut 2 inches of pipe cleaner for each double wing and apply a little adhesive to the pipe cleaners; stick the pipe cleaners between the felt wings, along each curve, bending them to follow the curves. Pad the rest of each wing with a little cotton and overcast the wings, to close. Work lines of running stitch in white thread through all thicknesses, as indicated, to suggest feathers. Overcast wings from A to B, to the base of each swan, as shown in picture.

Snakes

Each snake consists of four pipe cleaners twisted together and bound with thick knitting yarn until the felt covering fits snugly.

Body coverings: Cut four strips of felt, each $6\frac{3}{4}$ inches by $\frac{5}{8}$ inch, two in bright pink, one in mauve and one in emerald green. Overcast one long edge of the mauve strip and one bright pink strip, to join, and repeat with other strips. Wrap one joined strip around one snake body and overcast to join, adding cotton padding if necessary. Gather the short edges of the strip and overcast. Repeat.

Heads: For each head, cut two felt pieces, each 1 inch square, from the body colors. Overcast two sides of one pair of felt pieces, put the tube over one end of the snake, gather, and pad, matching the colors to the body. Repeat. Decorate as shown in picture, placing sequins or fancy braid down the back of the snakes.

Features: Make eyes as shown. Embroider mouths on each snake as shown, then cut a $1\frac{1}{4}$ inch length of thin brass wire for each tongue. Twist tiny black beads on the ends of the wire and fold the wire in half. Poke a tiny hole in snake's head, just above the center of the mouth, insert the folded end of the wire and stitch securely in place. Repeat.

Ark

You will need:

- One cardboard box (the one illustrated measures $13\frac{1}{2}$ inches by 7 inches, $4\frac{1}{4}$ inches deep)



[Vintage Patterns Dazespast](#) (re-mastered eBooks)

[Dazespast](#)

Original Vintage Knitting Crochet, Sewing & Needle Art Patterns and Books
eBay Store: mooreruby817

Free Vintage Patterns for Everyone
[Livin a Vintage Lifestyle and Lovin It](#) (Facebook)

[Follow Us on Pinterest](#) or the [Vintage Patterns Blog](#)

Email: ruby@dazespast
315.317.0781 Fax same